

Using Belleville Springs To Maintain Bolt Preload

George P. Davet, B.S.M.E.
Solon Mfg. Co.

TABLE OF CONTENTS

1. INTRODUCTION
 - 1.0 What is a Belleville Spring?

2. PRINCIPLES OF BELLEVILLE SPRINGS
 - 2.0 Why Does a Bolt Loosen?
 - 2.1 The Joint Diagram
 - 2.2 Using Belleville Springs to Maintain Bolt Preload
 - 2.3 Movement in Flanged Joints
 - 2.4 Bus Conductors and Differential Thermal Expansion

3. TESTING
 - 3.0 Test of Bellevilles Used on a Bolted Joint
 - 3.1 Tests of Bellevilles Used on a Flanged Joint
 - 3.2 Conclusions of Flange Tests

4. BELLEVILLE SPRINGS IN PRACTICE
 - 4.0 Designing a Live Loaded Joint System
 - 4.1 A Practice Problem

5. REFERENCES

1. INTRODUCTION

1.0 What is a Belleville Spring?

A Belleville Spring is a conical shaped disc that will deflect (flatten) at a given spring rate when subjected to an axial load F_p (Figure 1). This rate is usually very high relative to a coil spring, which makes a Belleville an excellent candidate where large loads must be delivered through a short movement. Some applications where Bellevilles are commonly found are: clutch and brake mechanisms in heavy equipment, punch and die sets, bearing assemblies, switchgear, and anywhere bolt pre-load must be maintained over time.

A Belleville Spring's geometry can be characterized by four dimensions:

- OD = outside diameter
- ID = inside diameter
- t = material thickness
- h = deflection-to-flat

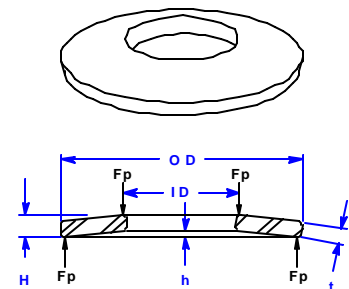

Figure 1 A section of a Belleville Spring showing load F_p applied at the "upper-inside" and "lower-outside" corners.

Some manufacturers use the parameter H (free height $t+h$) in lieu of h . In a bolted joint the spring is normally loaded at the upper-inside edge by the nut or bolt head and the lower-outside edge by the joint.

Manufacturers also use a parameter called "flat-load" or "load-to-flat" (F_w) in their description of a Belleville Spring. This is the force required to "push" the spring into the flat position. As the nut in a bolted joint is torqued the spring starts to deflect (flatten) and the bolt begins to stretch. The Belleville will be in its flat position when the preload in the bolt equals the flat-load¹. Since the spring will be clamped between the flat joint and the nut, any additional torque applied to the nut will only stretch the bolt. Higher loads (than F_w) will normally not damage the spring if the load cannot deflect it past the flat position (as in most bolting applications). Therefore, the maximum force that can be applied to a Belleville mainly depends on the limitations of the bolt or joint designs.

The spring rate of a Belleville depends on geometry, material, and loading conditions. A plot of load versus deflection will show that the Belleville's characteristic curve is linear up to about 90% of the flat load.¹ After 90% the load increases progressively because the spring begins to bottom out. Figure 2 shows a typical load deflection curve of a single Belleville. Note that for a given deflection the decreasing loads are lower than those on increasing. This hysteresis is caused by the friction between the spring and the loading surfaces.

¹This applies to most Bellevilles that are used in bolting applications; however, springs can be designed to have a non-linear characteristic curve.

The load/deflection relationship can be altered by using multiple springs in series or parallel or a combination of both (Figure 3). Bellevilles are said to be in series when the concave and convex surfaces alternate the direction they are facing [1]. In other words, they are stacked "cup to cup" and "crown to crown." Springs stacked in parallel face the same direction. The convex side of one spring is "nested" into the concave surface of the next. Bellevilles may also be arranged in "series-parallel" by alternating sets of springs stacked in parallel.

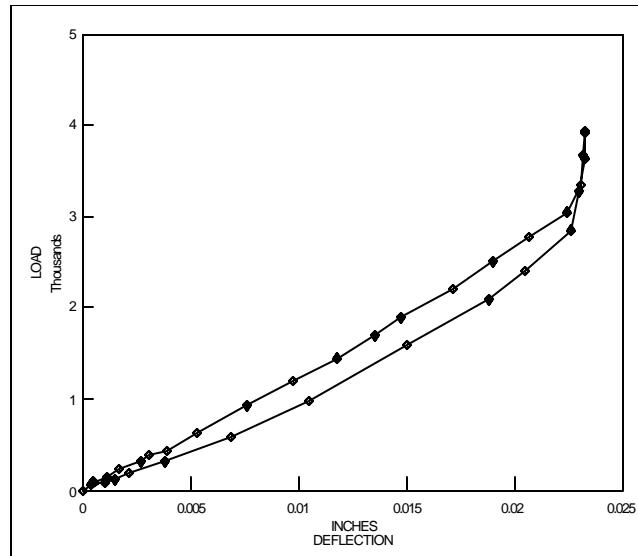

Figure 2 Load deflection curve for a single Belleville Spring. The upper curve represents an increasing load while the lower curve shows the spring unloading.

Two springs stacked in parallel doubles the load required to flatten the springs with no increase in deflection. Two Bellevilles stacked in series will produce twice the deflection for the same load. Figure 4 shows the load deflection curves for various combinations of springs. The frictional hysteresis increases as more springs are used in parallel because the larger contact areas result in higher frictional forces. These forces are decreased as more washers are used in series since some of the contact surfaces will "roll" rather than "slide."

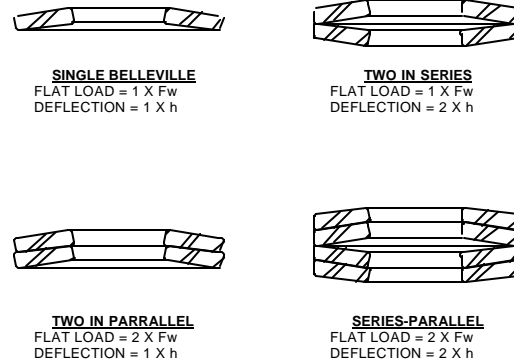

Figure 3 Flat load, deflection, or both may be altered by stacking Belleville Springs in various arrangements.

2. PRINCIPLES OF BELLEVILLE

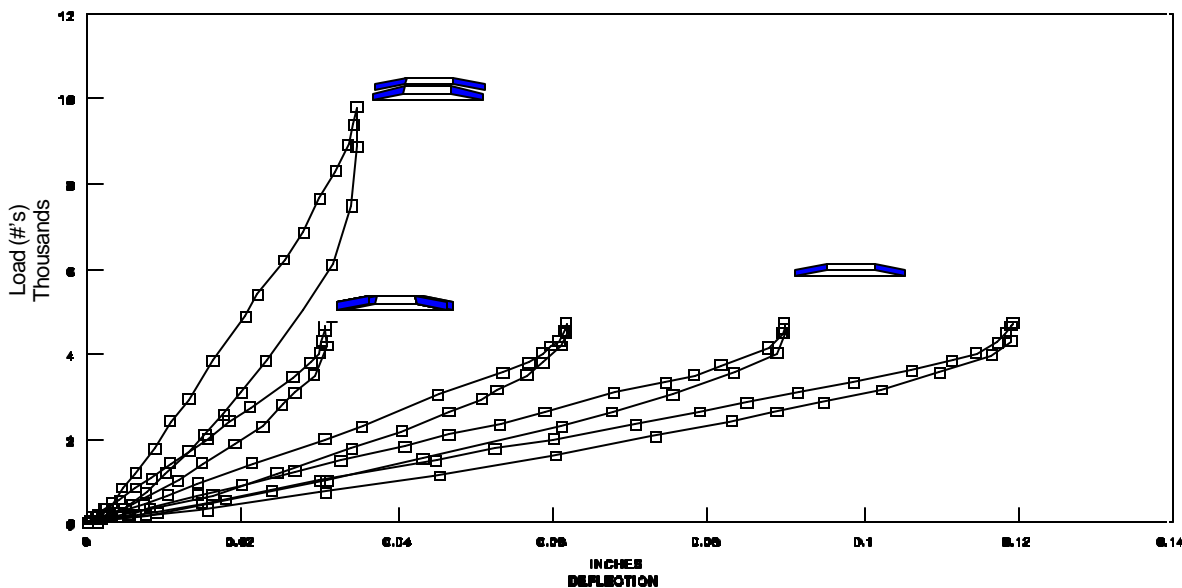

Figure 4 Load deflection curves of several different Belleville arrangements. This shows that adding springs in series increases deflection without increasing load, while using springs in parallel multiplies

SPRINGS

2.0 Why Does a Bolt Loosen?

After a bolted joint is assembled, some of the original preload is almost always lost. This happens because the components of the joint immediately begin to relax and move. If the joint is a flange with a gasket, the losses become more severe over time. This is especially true if it is subjected to wide temperature cycles. Some of the phenomena that cause preload to be lost at assembly and over time are briefly described below:

1. *Embedment Relaxation.* When new studs and nuts are tightened onto the joint, the components contact each other only on microscopic high spots. Since these high spots will be overloaded, they will yield. As this yielding occurs the bolts will relax and the contact area will increase. It is estimated that when the system finally stabilizes that as much as 5-10% of preload may be lost to embedment relaxation.
2. *Gasket Creep.* Gaskets are designed to creep and flow into the crevices of the joint surfaces when subjected to high surface loads. This is absolutely necessary to ensure performance. As plastic flow occurs the flange faces will come closer together slightly. This results in some loss of preload. The amount that is lost is primarily a function of the gasket material and design. Tests sponsored by the Subcommittee on Bolted Flange Connections of the PVRC reveal that creep in some spiral wound gaskets only account for a 2-5% loss in preload at room temperature. For PTFE based gaskets this value can be higher. Increased temperature will also cause gaskets to creep but the effect on preload varies from gasket to gasket.
3. *Bolt Creep.* Bolts used in high temperature service will tend to relax over time. The amount of preload lost depends on the bolt material, temperature, and length of time at temperature.
4. *Vibration.* Under severe vibration fasteners will lose preload very slowly at first. When the tension falls below a critical value, the rate of relaxation increases as the surfaces between the male and female threads begin to slip.
5. *Elastic Interactions.* This phenomena can be avoided if all of the bolts in a joint are tightened simultaneously. In the real world, however, this rarely happens. On flanged joints, for instance, the bolts are tightened in stages using a crossing pattern. The first pass is tightened to approximately 30% of the final desired preload. The next two passes would be at 60% and 100% of desired preload. Some assemblers also conduct an extra pass at 100% in reverse of the crossing patterns employed in the first three passes.

Elastic interaction is occurring between the bolts and the joint members during this entire process. When the first bolt is tightened, the fastener is stretched and the joint is partially compressed. When an adjacent bolt is tightened, the joint in the vicinity of the first bolt is further compressed. This allows the first bolt to relax somewhat. Even if the amount of preload applied to each bolt is precise, only the second bolt will have that preload. The amount of preload lost in elastic interactions depends on the gasket type and the stiffness of the bolting system.

6. *Differential Thermal Expansion.* As temperature rises most materials expand. In flange applications heat usually comes from the process media. Since the flange and gasket are in closer contact to this process fluid they will tend to heat (and expand) faster than the bolts. As the joint members expand the tension on the bolts increases, which further stresses the gasket. The increase in gasket stress will cause it to be compressed more than it was at assembly. When the system cools down all of the joint members will return to their original thickness. Since the gasket is not fully elastic it will not return to its initial compressed thickness. This will result in some loss of preload. The amount lost depends on the stiffness of the fastener system, gasket type, temperature and the rate of rise, and the number of cycles.

2.1 The Joint Diagram

As mentioned in section 1.0, when a bolt is tightened to a given preload, it stretches by a certain amount. At the same time, the joint will compress proportionally². This always will happen, regardless of how small the preload is or how stiff the components may seem. This fact is exactly why bolting works.

One of the keys to good bolting is to understand the various loads and deflections present in a joint. If this is accomplished, then the engineer stands a better chance of getting the various deflections to work in their favor. If the joint can be modeled as a system of springs, then predicting changes in preload becomes relatively easy. A joint diagram is simply an illustration of the various spring rates present in a bolted joint. This tool is designed to allow the engineer to predict the change in preload through external loads or relaxations [2].

The following example will illustrate how a joint diagram is constructed. Assume that a bolt has a spring rate that is 40% the rate of the joint. In other words, if the bolt deflection at a given preload is .005" then the joint compression at the same load would be .002". A plot of load versus deflection for a bolt is shown at the upper left portion of Figure 5. If dL is the amount of stretch in the bolt at an aim preload F_P , then the spring rate of the bolt K_B can be computed:

Furthermore, if the amount that the joint compresses at F_P is dT , then the spring rate of the joint K_J is:

$$K_B = \frac{F_P}{dL}$$

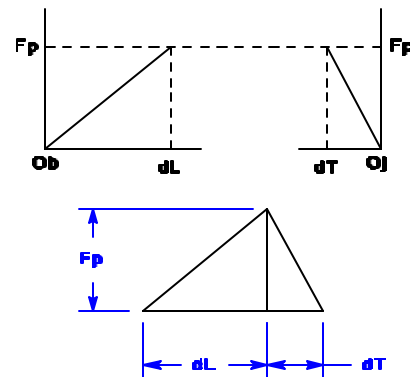

Figure 5 A joint diagram where F_P = aim preload; dL = bolt stretch; dT = joint deflection. Here the joint is very stiff compared to the bolt.

When the two plots are combined, a joint diagram is formed. At this point, the bolt load is equal to the clamping load.

²This assumes that the joint behaves elastically.

$$K_J = \frac{F_P}{dT}$$

In order to understand how a joint diagram is used to analyze a joint, consider an external load L_x is applied to the system. For instance, assume that a tensile load L_x is applied to the bolt where the face of the nut contacts the joint (Figure 6). This interface will be known as the "loading plane." As the bolt is pulled, the load on the bolt F_B is increased while the clamp load on the joint F_J is decreased. When the system was first assembled, these two loads were equal to the preload F_P . As the external load is applied to the bolt, the joint starts to return to its unloaded thickness along the elastic curve. At the same time, the bolt is elongated by the combined force of the joint "pushing" out on the nut and the external load. Note that since the nut stays in contact with the joint while the external force is applied, the change in deflection in the bolt and the joint are equal. In other words, the bolt gets longer by the same amount the joint becomes thicker.

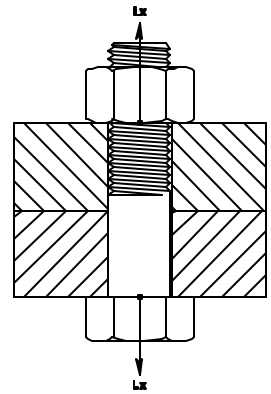

Figure 6 A section of a joint showing the application of external load L_x at the loading plane (where the nut and bolt head contact the joint surfaces.)

Figure 7 is the joint diagram showing the effects of an external load L_x . Since the bolt is more elastic than the joint, any increase in load on the bolt dF_b results in a larger decrease in clamp load on the joint dF_j . Another way to look at it is in terms of how deflection of the bolt effects clamp load. As the bolt is stretched from dL to dL' , a significant amount of clamp load is lost. In Figure 7 the bolt is stretched an extra .001". The result in this example would be a 50% decrease in clamp load F_j .

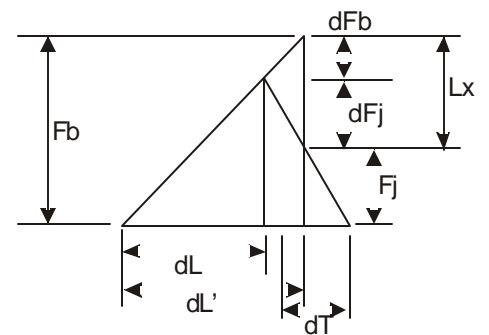

Figure 7 Joint diagram where L_x = external load; dL' = new bolt stretch; F_j = load remaining on the joint = $(.5) \times F_p$.

2.2 Using Belleville Springs to Maintain Bolt Preload

The spring rate K_w of a single spring is about 1/3 to 1/7 of the bolt's rate (K_B). This is because a Belleville will deflect three to seven times more than a bolt will stretch at a given preload³. This is true until the preload begins to exceed the flat-load of the spring (or spring assembly).

Remember that after the Belleville has been flattened, any additional load will only stretch the bolt and compress the joint. For this reason, springs should be selected with flat-loads that are close to the preloads to be used (for bolting applications). If the flat-load is much greater than the preload, then the Belleville will only be partially compressed. Since only a fraction of the spring's potential deflection is used, the engineer is not maximizing its benefits. If the preload is greater than the flat-load, then the Belleville will remain in its flat position until the residual preload falls below the flat-load.

The joint diagram discussed in section 2.1 looks quite different if Belleville Springs are placed under the head of each nut. In order to properly analyze the joint the following assumptions will be made:

1. Assume that the loading plane is at the interface of the nuts to the Bellevilles. Therefore, the springs are part of the joint for this analysis. This assembly will be called the joint system. By adding the movement of the Bellevilles to the deflection in the joint the preload retained for a given external load can be determined.
2. The spring rate of each Belleville will be 1/4 the rate of the bolt. The rate of the joint will be consistent with the preceding example. Therefore, if the bolt stretches .005" at a given preload, then the joint will compress .002" and each spring will deflect .020".

The new joint diagram is shown below in Figure 8. Note that the slope on the bolt side of

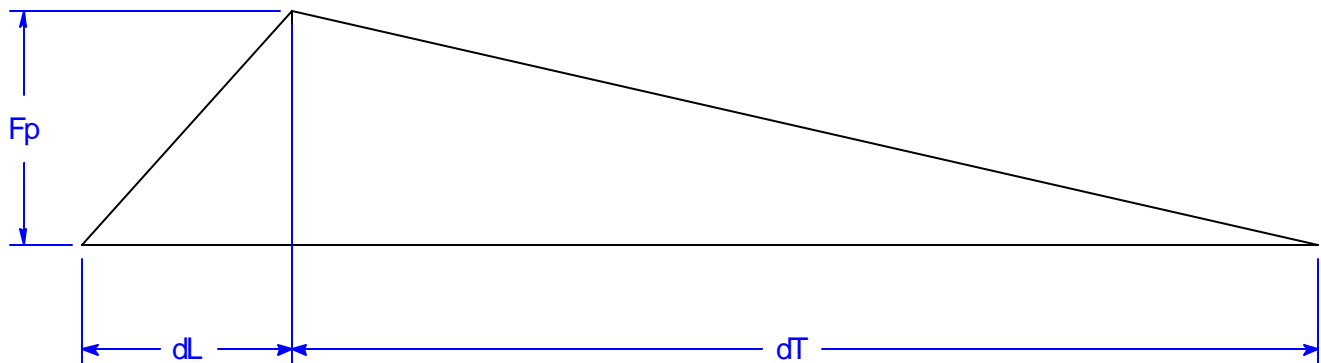

Figure 8 Joint diagram using Belleville Springs where $dL = \text{bolt stretch} = .005'$; $dT = \text{joint system deflection} = .002'' + 2x(.020'') = .042''$. Now the joint is highly elastic compared to the bolt.

³ These figures are based on preloads that are below 60% of yield and length to diameter ratios lower than 12.

the diagram is very high compared to the joint side. With the Belleville Springs the joint system is now 1100% more elastic than without. This is because the total deflection of the joint system is equal to the movement in the joint sections plus two times the deflection of one spring (h).

An external tensile load is now applied to the bolt by pulling on the nut and bolt head. The change in load on the joint system dF_j is very small compared to the external load (see Figure 9). Without the Bellevilles the external load that resulted in a 50% loss of load on the joint now causes a 2.4% loss. This is because originally the joint was very stiff compared to the bolt. By adding springs the joint system has become 21 times more elastic.

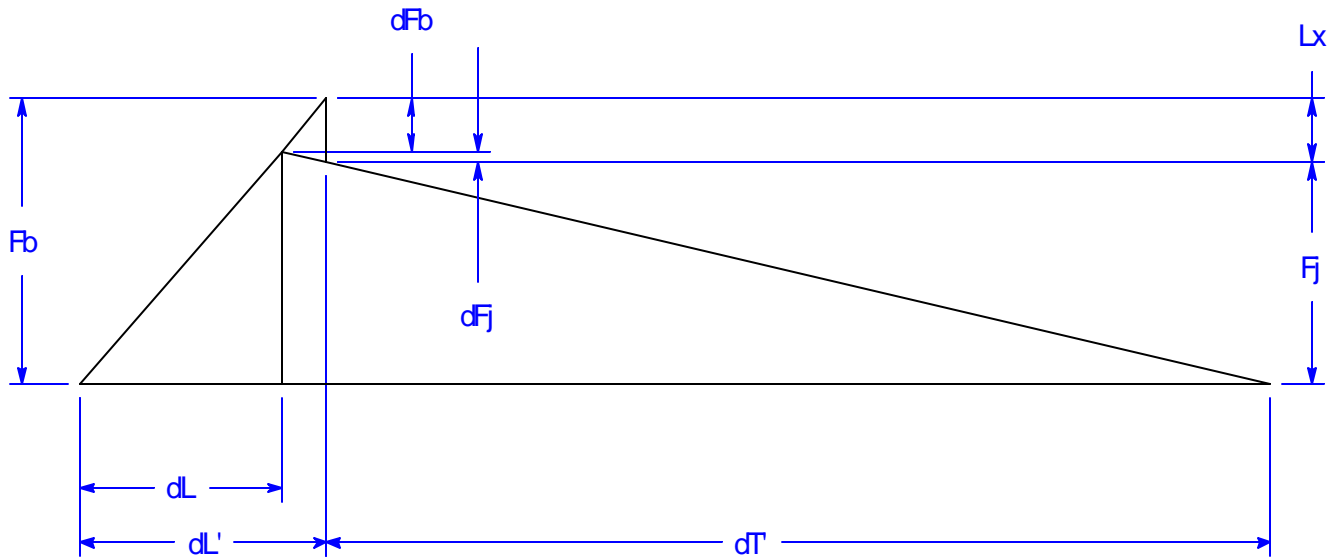

Figure 9 Joint diagram using Belleville Springs where L_x = external load; dL' = new bolt stretch; F_j = load remaining on the joint = $(.976) \times F_p$.

2.3 Movement in Flanged Joints

In the real world, it is very rare to see external loads applied to a bolt once it is in service. A more likely situation is one in which there is some "movement" in the joint. In other words, the joint faces are allowed to come closer together because of unloading of the joint (such

as creep or yielding of the gasket material³). In order to use the joint diagram to analyze this scenario it is important to think in terms of movement rather than changes in load. In the previous section, the joint diagram was used to determine clamp load on the joint when an external load is applied to the bolt. Here clamp load will be calculated based on how much the joint or bolt move (due to creep, yielding, thermal expansion, etc.). If the amount of movement in the joint can be predicted then the change in force applied to the joint can be determined. The following assumptions will be made:

1. There is some sort of elastic material, such as a gasket, between the two sections of the joint. Although the loading curve of most gasket materials is nonlinear, the unloading rate is fairly constant [3]. For the purpose of this analysis only, how a bolt's preload is affected by an unloading (creep, yielding, etc.) of the gasket material will be considered. Also, this unloading rate will be assumed, by coincidence only, to be equal to the spring rate of the bolt. The spring rates of the joint and Bellevilles will be consistent with the preceding example.
2. Deflection of the gasket will be measured between the faces contacting the surface of the gasket. The load at this interface is critical since this is where leaks normally occur. For the purposes of this discussion, this will be called the loading plane (even though no external loads will be applied here⁴). Keep in mind that gasket relaxation or yielding will cause unloading rather than loading [4].
3. Since the loading plane is now at the faces of the joint (contacting the gasket), the deflection of the Bellevilles and the joint sections must be added to the bolt stretch. The sum of these deflections will make up one side of the joint diagram while the gasket unloading rate will make up the other.

Figure 10 illustrates what happens in theory when there is relaxation in the joint that uses no Bellevilles. For this joint diagram:

³Movement in the joint might also refer to unloading due to creep or relaxation of the joint or bolt materials if there is no gasket. An example of a gasketed joint will be used here because the amount of movement is typically more severe. Use of Bellevilles in a non-gasketed joint is reviewed in the next section.

⁴The term "loading plane" may also refer to the plane at which changes in load are measured rather than applied.

dL_f = fastening system deflection (includes bolt and joint);
 dL_g = elastic portion of gasket deflection;
 F_g = original load on gasket;
 F_g' = present load on gasket;
 R = gasket relaxation.

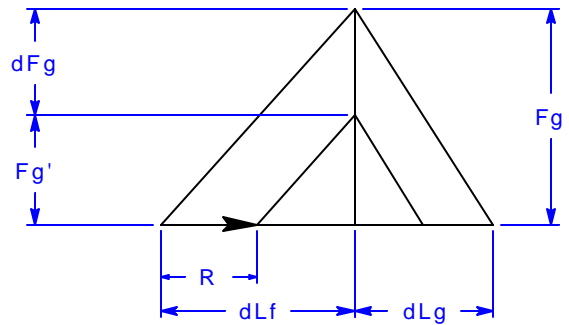

Figure 10 Joint diagram where dL_f = fastening system deflection = .006"; dL_g = gasket deflection = .003"; F_g = load on the gasket R = gasket relaxation = .003"; F_g' = residual gasket load = (.5) \times F_g .

The key to this analysis is understanding the dimension for gasket relaxation R . As load is applied to the fastener, the gasket and joint sections are compressed and the bolt is stretched. When the desired preload is reached, the gasket material will have a given thickness (equal to the distance between the inside faces of the joint sections). This dimension will change over time due to many phenomena such as elastic interactions, gasket creep, differential thermal expansion, etc.⁶ The amount by which the gasket thickness decreases is R . Note that R is on the fastening system side of the joint diagram (Figure 10). This is because as the faces of the joint move together by the dimension R , the fastening system is unloaded. Since R is strictly a change in dimension, it should have no effect on the slope of the diagram. It's as if the point of origin of the fastening system side of the diagram has "slipped" or moved by R . The entire joint diagram becomes smaller, resulting in a lower residual preload. Preload lost is strictly a function of the amount of the relaxation and the spring rate of the fastening system.

The example in Figure 10 might have the following parameters [5]:

- Bolt Stretch = .005"
- Joint Deflection = .001"
- Gasket Deflection (dL_g) = .005"
- Relaxation (R) = .003"

Since the amount of preload lost due to a give relaxation R is equal to R/dL_f , then;

$$\frac{R}{dL_f} = \frac{.003}{.005 + .001} = \frac{1}{2} = 50\%$$

of the original preload would be lost. This explains why so many gasketed joints that are subject to thermal cycles begin to leak after a short time. This analysis reveals that a relatively small relaxation results in a substantial decrease in preload.

Figure 11 is the same joint with Belleville Springs added. If two Bellevilles are used that have a total deflection of .040" then dL_f increases from .006" to .046". If the same

⁶ The dimension will normally become smaller since most of these phenomena rob the fastener of preload.

figure for R is used, then:

$$\frac{R}{dLf} = \frac{.003}{.005 + .001 + .04046} = \frac{3}{46} = 6.5\%$$

of the original load would be lost to relaxation. In order to lose as much load as was lost without springs relaxation R would have to increase by 460% (.014"). Using Bellevilles in this manner to improve retained preload is commonly known as "live loading" the joint. Live loading is effective because most gaskets do unload after installation. Increasing the fastening system deflection (dLf) reduces the effect of this phenomena. The ratio of total R to dLf simply becomes smaller.

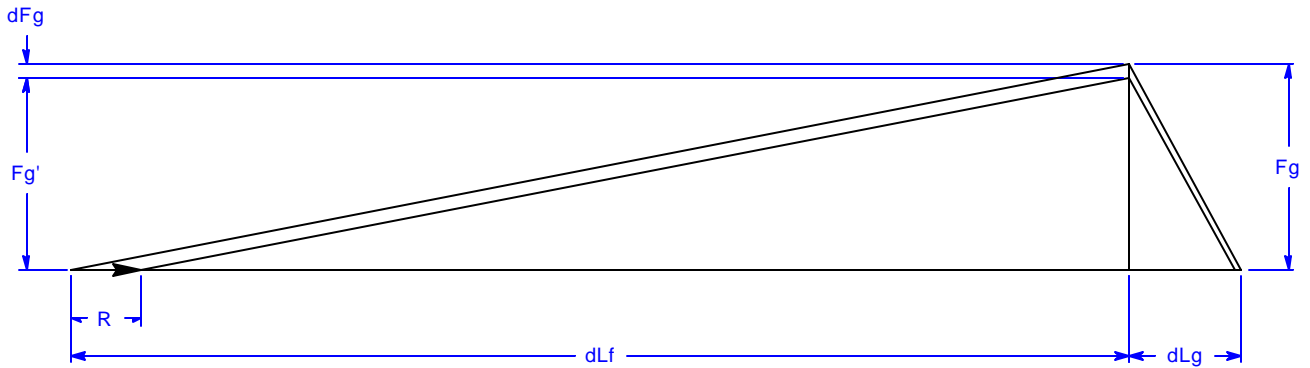

Figure 11 Joint diagram using Belleville Springs where dLf = fastening system deflection = .046"; Fg = load on gasket; R = gasket relaxation = .003"; Fg' residual gasket load = (.935)xFg.

2.4 Bus Conductors and Differential Thermal Expansion

Bellevilles are not only used in gasketed joints. Using springs to compensate for unloading due to differential thermal expansion in electrical bus conductors is another very common application. Bus conductors are used for electrical circuits, usually carrying high voltage and current) [7]. This can be very similar to a gasketed joint. When bus conductors are joined (see Figure 12) a joint system consisting of two or more sections of bus bar made of soft aluminum is typical. The fastening system consists of bolts, flat washers, and (usually) Belleville Springs. These components are often made from non-magnetic and corrosion resistant materials, such as stainless steel.

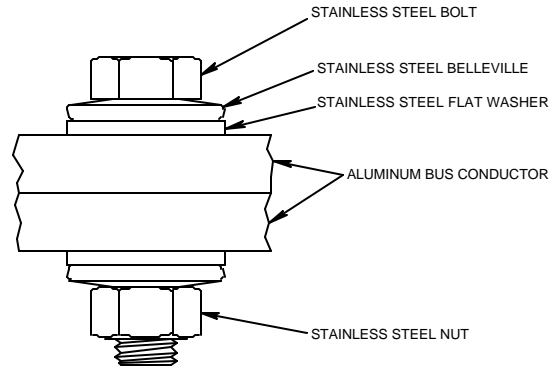

Figure 12 Components of a typical bus conductor joint.

In a bolted bus connection, heat is produced from two sources: the resistivity of the bus bar material itself and that generated by the contact resistance at the interface of the bus bar sections. In a well designed joint, the heat will be dissipated by radiation and convection to the atmosphere. If more heat is generated at the contact interface than can effectively be dissipated, a "hot spot" temperature rise will occur. This originates in an area where the joint pressure is highest since this is where the majority of the current is carried. When pressure is concentrated around the bolt hole, the soft bus material is relatively free to flow in toward the bolt. The increased temperature causes a higher rate of creep. As the bus bar material creeps, contact pressure falls and resistance increases until the joint fails. In order to prevent this, the "efficiency"⁵ of the joint must be maximized. First, a sufficient number of fasteners must be used to produce enough contact pressure. Next, even distribution of fastener preload will prevent high concentrations of stresses in the vicinity of the bolt holes. This can be accomplished by using flat washers on both sides of the joint (it is not recommended that Belleville Springs be used without flat washers since its lower outside corner will tend to "dig" in to the soft bus material). Finally, a minimum residual preload must be maintained when creep or relaxation occurs. An effective way to do this is to employ Belleville Springs.

The benefits of using Bellevilles in bolted bus conductors can be demonstrated with the joint diagram. The following assumptions will be made for this analysis:

1. The bus bar will be fabricated from two 1/4" thick sections of EC-H13 aluminum.
2. For the first analysis (where no springs are used), the fastening system will consist of a " stainless steel bolt and two 1/8" thick stainless flat washers. In the second case,

⁵"Efficiency" is defined in this case as the ratio of the bolted joint resistance to the resistance of an equivalent length of solid bus material.

two 1/8" thk. stainless Bellevilles will be used along with the flat washers. The flat load of the springs will be 7100 lbs.

3. The temperature at assembly will be 70F. With the conductor in service the bus temperature in the vicinity of the bolt will reach 220F. Since the bolt carries no current, its temperature will only reach 150F.
4. For simplicity, the assembly preload will be equal to the flat load of the Belleville, 7100 lbs

If the loading plane is the joint interface between the washer face and the bus bar, the diagram would look like the one shown in Figure 13.a⁶. On the left side is the joint with a deflection of d_T at load F_p , while the right side is the bolt with stretch d_L at F_p . The dashed line represents the continuation of the elastic curves for the bolt and the joint at higher loads. Note that the elastic curve for the joint begins to "flatten out" above F_p . This is because the soft joint material yields at relatively low levels of stress. The drawing to the right of the joint diagram shows a load (L_x) that is applied at the loading plane. As L_x is increased, the joint is unloaded while the bolt is loaded. In other words, L_x will reduce joint deflection and increase bolt stretch.

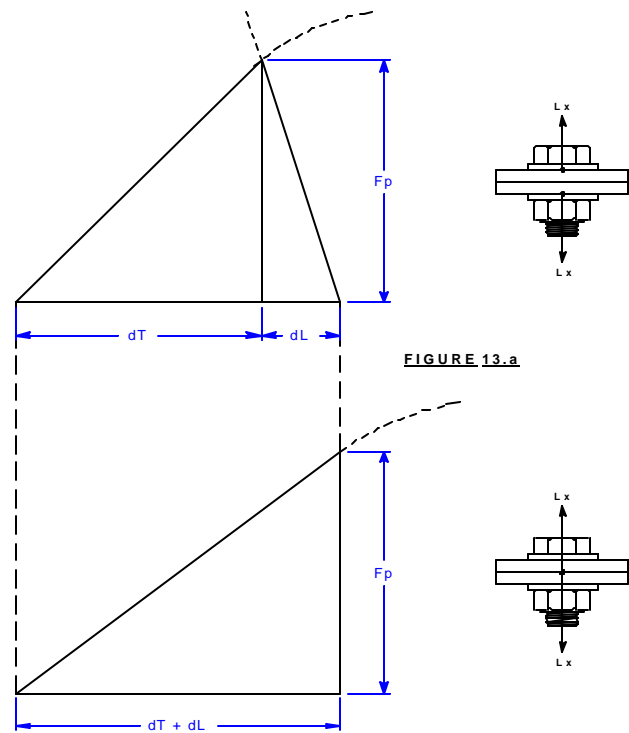

FIGURE 13.a

Now, for a bus conductor connection, the load at the joint interface of the two sections of bus bar is of greatest interest. This load is directly related to the contact resistance (and efficiency) of the joint. Therefore, the loading plane used for this analysis will be shifted to the center of the joint (see Figure 13.b). There will no longer be two "sides" to the joint diagram. This is because any load L_x will increase load on both the joint and the bolt. Since L_x increases bolt stretch and joint deflection, these values should be on the same side of the joint diagram. When the preload F_p is applied, the horizontal leg of the diagram will equal the sum of the deflection in the joint and the stretch in the bolt = $d_T + d_L$.

Figure 13 Shows joint diagram with different loading plane positions. When the loading plane in moved to the center of the joint, the diagram has only on eside because a change in L_x has the same effect on all of the components. in other words, as L_x increases, the bolt, joint, washers, and Bellevilles are loaded.

⁶This is similar to the joint discussed in Section 2.1.

For this example, the assembly preload is 7100 lbs. Since the joint had hardly yielded at this point, the diagram is basically a right triangle. At this preload, the deflection of the joint is .0052" and the bolt stretch is .0017"⁷. Therefore, the horizontal leg of the triangle is .0052" + .0017" = .0069".

As stated earlier, when current begins to run through the conductor, the assembly begins to heat up. Using the assumed service temperatures and material properties, the change in lengths ΔL of the bolt, joint, and flat washers can be determined using the following equations:

$$\Delta L_B = r_B * L_B * \Delta T_1$$

$$\Delta L_J = r_J * L_J * \Delta T_2$$

$$\Delta L_W = r_W * L_W * \Delta T_1$$

where,	B	=	coefficient of thermal expansion of the bolt material
		=	6.4 X 10 ⁻⁶ in/in/F
	J	=	coefficient of thermal expansion of the joint material
		=	12.8 X 10 ⁻⁶ in/in/F
	W	=	coefficient of thermal expansion of the washer material
		=	6.4 X 10 ⁻⁶ in/in/F
	L _B	=	grip length of the bolt = 1.25 in.
	L _J	=	thickness of the joint = 1.00 in.
	L _W	=	thickness of a washer = 0.125 in.
	T ₁	=	change in temperature of bolt and washer = 150F - 70F
	T ₂	=	change in temperature of joint = 220F - 70F

Therefore,

$$\Delta L_B = 0.0006 \text{ in.}$$

$$\Delta L_J = 0.0019 \text{ in.}$$

$$\Delta L_W = 0.00005 \text{ in.}$$

Note that the joint expands more than the bolt does. This will cause an increase in preload. The change in load caused by the differential thermal expansion F_T^8 can be found using the following equation [2]:

⁷Joint deflection was determined empirically while bolt stretch was calculated using Hooke's Law. The yield point of the bus bar was found through testing to be 7,000 lbs.

⁸This equation is based on a linear elastic curve. Actual increase in load may be slightly less because of yielding of the joint. On the other hand, loads may be increased since the yielding will cause temperature (and differential thermal expansion) to increase. Each of these phenomena should offset each other which would lead to fairly accurate results.

$$F_T = \frac{K_B * K_J}{K_B + K_J} * (\Delta L_J + 2 * \Delta L_W + \Delta L_B)$$

where K_B and K_J are the spring rates of the bolt and the joint, respectively⁹. Using the figures for the spring rates and expansions calculated earlier, the increase in preload F_T is 1,425 lbs. This increase is reflected on the joint diagram in Figure 14. Remember that the elastic curve is non-linear above the preload because the joint begins to yield at 7,000 lbs.

When the temperature returns to 70F, the residual preload will be lower than at assembly (represented by dashed line in joint diagram). Note that the load on decrease is parallel to the linear portion of the elastic curve. This is because yielding in the bus bar material had effectively shifted the joint diagram. For this example, an increase of 1,425 lbs. will result in a yield of 0.0015". A 0.0015" shift will cause residual preload to fall to 5,550 lbs. (a 22% decrease). Since the lower preload will increase contact resistance, as current runs through the conductor more heat will be generated. This will not only increase the differential thermal expansion, but may also cause the joint material to unload even more due to creep. Each time the bus conductor is cycled more load will be lost until the connection eventually fails.

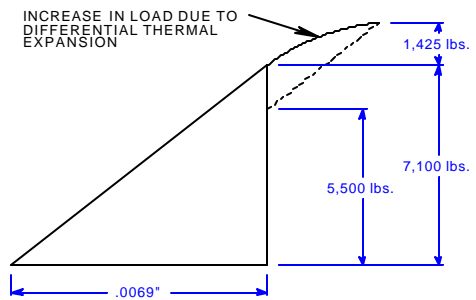

Figure 14 Joint diagram showing the yielding of aluminum as load is increased by 1,425 lbs. due to differential thermal expansion. The dashed line reveals that preload will fall to 5,500 lbs as temperature returns to 70F.

Now consider the case where Bellevilles are used. Assume that two springs in series with .019" of deflection (h) are used. The load applied to the bolt is the same as when no springs were used. Therefore, the vertical leg of the joint diagram in Figure 15 is the same (7,100 lbs.). However, the two Bellevilles have added $2 \times .019" = .038"$ to the horizontal leg. This decreases the slope of the elastic curve by a factor of 6.5. Since their materials and thicknesses are the same, the change in length of the Bellevilles will be the same as the flat washers (.00005"). Now, the change in load can be computed:

$$F_T = \frac{K_B * K_J}{K_B + K_J} * (\Delta L_J + 4 * \Delta L_W + \Delta L_B)$$

⁹The spring rate of a flat washer is negligible.

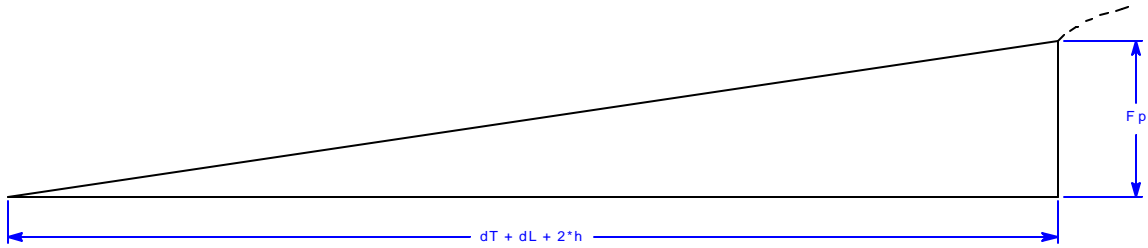

Figure 15 Shows the joint diagram using two Belleville Springs with the loading plane at the center of the joint. Note the elastic curve changes slope (dashed line) if load is increased beyond 7,100 lbs. This is because the springs are flat at this point.

Note that this formula is virtually the same as the one used for no Bellevilles. The only differences are that the change in length of the washers is multiplied by four rather than two and the bolt length is 1/4" longer. This accounts for the two Bellevilles. The spring rates of the Bellevilles are not in the equation because they are in the flat position when the preload is 7,100 lbs. Plugging in all of the numbers yields an increase in preload F_T of 1,347 lbs. The increase in load is shown by the solid line on the joint diagram in Figure 16. Note that when load is raised above 7,100 lbs., the slope of the elastic curve increases. This is because the springs will no longer deflect beyond their flat load. The joint material will yield as if there were no Bellevilles. However, as the components return to their original temperature, preload falls quickly until the flat load of the springs is reached. Then the Bellevilles begin to unflatten slightly to "absorb" some of the change in load. This is why the unloading line changes slope (see the dashed line in Figure 16) at the flat load of the springs. For this example, the differential thermal expansion resulted in only a 3.4% decrease in preload. This a substantial improvement over the 22% lost when no springs were used.

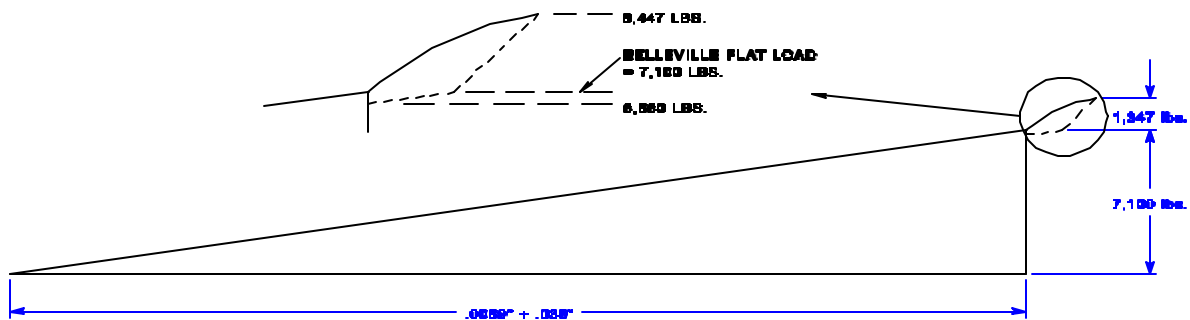

Figure 16 With Bellevilles, the differential thermal expansion causes a 1,347 lb. increase in load. However, when temperature returns to 70F, the joint unloads (along the dashed line) at a steep rate until the flat load of the springs is reached. Then the bellevilles begin to "absorb" some of the change in the load so that residual preload only falls to 6,860 lbs.

The next time the bus conductor is cycled, the increase in preload will be much smaller. Because the Bellevilles are no longer flat, their spring rate can be incorporated into the formula for change of load due to differential thermal expansion:

$$F_T = \frac{K_S * K_B * K_J}{K_J * K_S + K_S * K_B + K_B * K_J} * (\Delta L_J + \hat{z})$$

where K_S is the spring rate of two Bellevilles. In this case, the differential thermal expansion will cause an increase of 237 lbs. Such a small increase in preload should not lead to any yielding of the bus joint. Therefore, when the assembly cools to ambient, preload will return to the same level. This is why many plant procedures call for the technician to tighten the bolt until the Bellevilles become flat, and then "back-off" 1/4 turn. Backing off allows the spring to unflatten by a small amount so that any differential thermal expansion will be "absorbed" by the Belleville. The example reveals that this practice is unnecessary. After a single thermal cycle, the spring unflattens slightly anyway.

3. TESTING

3.0 Test of Bellevilles Used on a Bolted Joint

The fixture shown in Figure 17 was designed to test the utility of Bellevilles in an actual joint. A piece of elastic gasket material was placed between two blocks of steel. Using the load cells, each stud was tightened to a preload of 4000 lbs. With a hydraulic press an external load (F) was then applied at the outer surfaces of the joint. As the external load was increased the movement of the joint was recorded using a dial indicator. At each respective increment of deflection the bolt preload was recorded. In other words, bolt load was observed as the joint sections moved closer together.

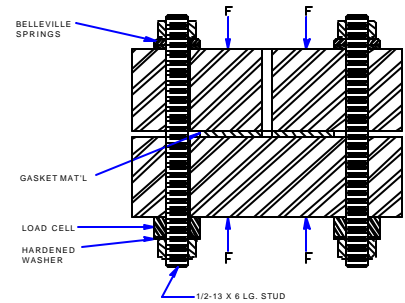

Figure 17 Drawing of a two-bolt test fixture used to test how preload falls as a gasket unloads.

The test was performed with and without Belleville Springs on the studs. The results are in Figure 18. In both cases as deflection increased (joint sections moved together) the bolt preload decreased. However, the amount of load that is lost was greatly affected by the spring rate of the fastening system. Note that the studs alone became completely unloaded at $.0095''^{10}$. When Bellevilles were used, over 62% of the original preload still remained at $.0095''$ deflection.

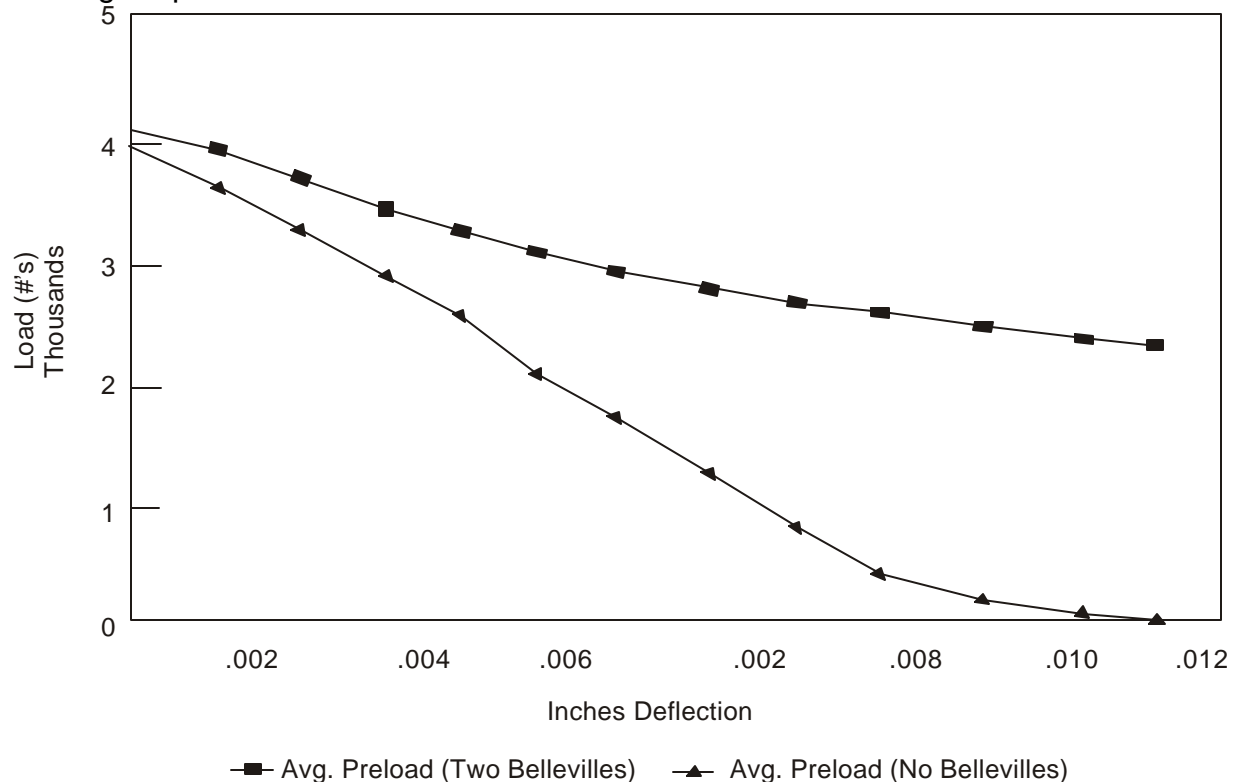

Figure 18 Graph of decrease in preload as a gasket unloads.

¹⁰Bolt stretch at 4000 lbs. was only about $.005''$. The reason it deflected $.0095''$ to unload the studs is because there was a total of $.0045''$ of movement between the fixture components and the hydraulic press that was used.

3.1 Tests of Bellevilles Used on a Flanged Joint

So far this paper has dealt with how Belleville Springs work in theory and on a two-bolt test fixture. The flanged system presents some additional problems to the engineer. Factors such as elastic interactions, embedment relaxation, and differential thermal expansion have negative impacts on preload. In order to properly evaluate the use of Bellevilles for live loading of flanges the following experiment was developed.

Two separate tests were performed for this experiment. The first test was done with no Bellevilles and the second with two springs in series. Variables such as temperature, lubrication, gasket type, pressure, and assembly method were held constant. The fixture in Figure 19 was designed to simulate a field situation. At one end of the pipe a plate was welded to allow the fixture to be bolted to the floor. At the other end was the flange system, a slip on flange and a blind flange. Inside the pipe, furnace elements were used to simulate a high temperature operation.

It was important to have the heating elements inside the test fixture in order to obtain realistic results.

There have been several testing labs which have attempted to simulate a high temperature process by placing a flange assembly into a furnace. When this is done the bolts heat up before the flange sections and the gasket stress is reduced. This is the opposite of what normally occurs in a high temperature process. By heating the fixture from the inside, the gasket stress is increased because the flange heats up faster than the bolts. This produces more realistic results.

Standard parts and components that were employed include:

1. Class 300 (ASME B16.5) slip-on and blind flange.
2. (16) 1" stud-bolts (A193 B7) with ball bearings embedded into ends.
3. 10" SCHD 80 pipe.
4. Spiral wound graphite filled gasket.
5. 16F30 flange washers (Belleville Springs).
6. Aluminum / Copper based antisieze compound.
7. 8-9" Micrometer.
8. Calibrated dial type torque wrench.

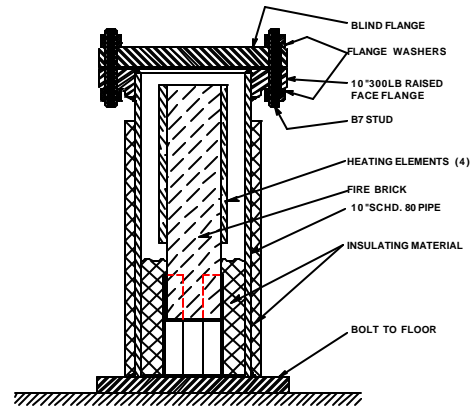

Figure 19 Drawing of flange fixture designed to show preload is affected by assembly procedure, use of Bellevilles, and thermal cycles.

With the gasket between the flange faces, the studs were assembled to finger tight. The length of each stud was then carefully measured using micrometers. In order to provide fast, consistent readings, ball bearings were embedded into the ends of the studs. Anvils with coined indentations were also installed over the micrometer tips. The studs were numbered from 1 to 16, and they were arranged in order around the flange (Figure 20.) Their position in the bolt circle was maintained through all of the tests for control.

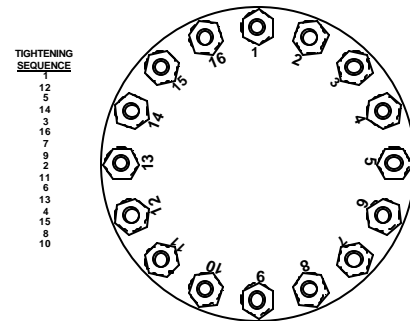

Figure 20 Stud position and tightening sequence used for this experiment.

The manufacturer of the gasket recommended that a bolt stress of 30,000 psi be used. This equates to a stud preload of 18,180 lbs. A final torque of 227 ft-lbs was calculated using a nut factor of 0.15¹¹ [8]. The first pass was made using a crossing pattern at 30% of the calculated final torque. The stud length was again recorded. The next two passes were at 60%, and 100% of final torque [9]. Using the changes in stud lengths, preload was calculated using Hooke's law. Graphical results of residual preload for the first three passes are shown in Figures 21 and 22 (after each pass stud lengths were recorded.) On the x-axis the stud position is displayed from left to right in the order they were tightened (Stud 1 was tightened first, stud 12 was tightened second, etc.). The y-axis is the calculated residual preload (based on the changes in their length.) Note that residual preload is the load

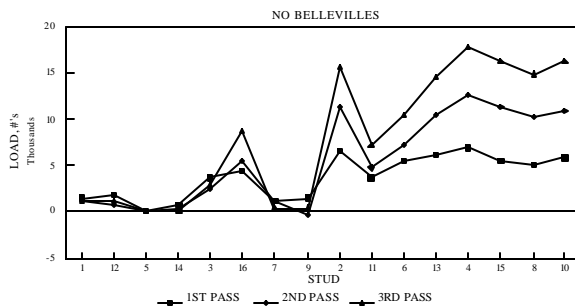

Figure 21 Residual preload for first three passes when no springs were used.

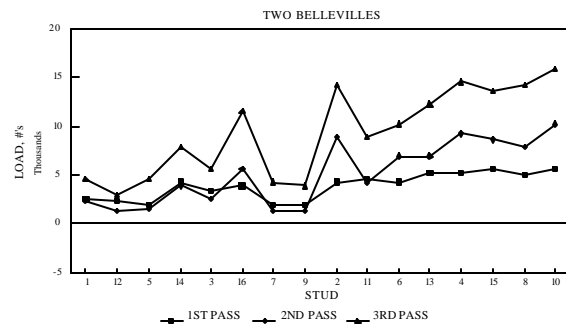

Figure 22 Residual preload for first three passes when two Bellevilles were used.

remaining in each fastener after the pass had been completed. Next, a reverse pass at 100% of the desired torque was executed (shown in Figures 23 and 24). The same procedure was followed for the tests which employed two Bellevilles.

The next step of the experiment was designed to demonstrate the effects of differential thermal expansion. After the final lengths were recorded the heating elements inside the pipe were turned on. The temperature within the pipe was raised to 1000F within one hour. Temperature was held for an additional two hours. The heater was then turned off and the assembly was allowed to cool down to ambient. Stud lengths were recorded. Figures 23

¹¹This was the nut factor recommended by the manufacturer of the anti-seize. This figure later proved to be low. However, in order to make use of all of the test results, 0.15 was used through the entire experiment.

and 24 show preloads after the reverse pass and after the assembly was exposed to high temperature.

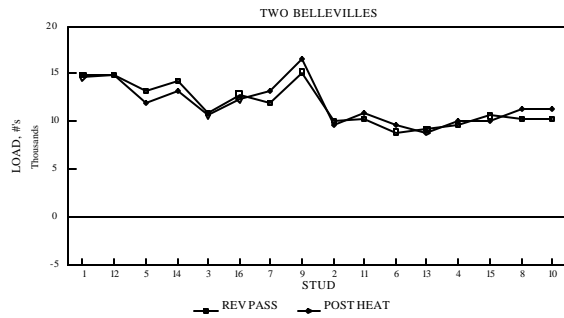

Figure 23 Residual preload for the reverse pass and after one thermal cycle when no springs were used.

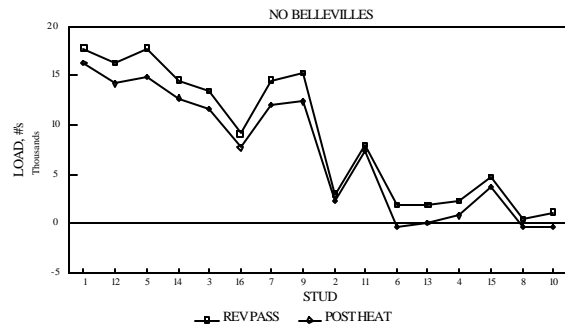

Figure 24 Residual preload for the reverse pass and after one thermal cycle when two Bellevilles were used.

3.2 Conclusions of Flange Tests

The results of the first three passes showed a marked reduction in preload scatter as the spring rate of the fastening system was reduced. This is because the *effects* of the elastic interactions were reduced. In other words, as the joint is pulled together by the tightening of each stud, adjacent studs are allowed to relax. Going back to the joint diagrams in Figures 10 and 11, the joint moves together by a dimension R each time a stud is tightened to a given torque. At the same time, the fastener has been stretched (and springs deflected) by a dimension dLf. The amount of preload lost in adjacent studs is proportional to the ratio R/dLf. If dLf is large compared to R, then elastic interactions will have a small impact on preload. Using Belleville Springs to live load the joint effectively increases dLf by increasing the deflection of the fastener system. When springs were not used it is apparent that at times the R dimension approached dLf (or even exceeded it.) This explains the very small preloads toward the beginning of each pass.

Next, the flange was thermally cycled. This caused additional stress to be applied to the gasket. The increase in load results in a small amount of gasket set, which may also be called R. Now that the flange faces have come together by R, the same R/dLf ratio applies to preload loss. The case where no Bellevilles were used (Figure 23) displayed a definite downward shift in preload. This is the reason that many plant procedures call for bolts to be retorqued after start-up. When the joints were live loaded the preload lost was immeasurable.

Figure 25 is a summary of the average preloads and standard deviations for the 16 studs.

	NO BELLEVILLES		TWO BELLEVILLES	
	<u>AVG. PRELOAD</u>	<u>STD. DEVIATION</u>	<u>AVG. PRELOAD</u>	<u>STD. DEVIATION</u>
1ST PASS	3726	2243	3905	1308
2ND PASS	5613	4745	5206	3122
3RD PASS	7999	6886	9338	4361
REVERSE PASS	8862	6486	11693	2123
AFTER HEATUP	7158	6100	11776	2116

Figure 25

In general, these results show that reducing the spring rate of the fastening system by live loading can reduce the effects of most of the phenomena that rob the bolts of preload. It must be noted that this tells us very little about their effectiveness of preventing leaks. Every one of these joints we tested may have been "leak free" in the field. On the other hand, each one may have failed under pressure. It is safe to say, however, that achieving and maintaining proper preload will greatly increase the likelihood of obtaining a sound joint.

4. BELLEVILLE SPRINGS IN PRACTICE

4.0 Designing a Live Loaded Joint System

The key to live loading a joint is to reduce the spring rate of the fastening system to a point where a threshold preload will be maintained. By maintaining this preload limit, the engineer should reduce the probability of joint failure. This will ultimately increase safety and reduce maintenance costs. Some of the criteria which should be observed are as follows:

1. *Is the joint even a candidate for live loading?* Most are not. The aim here is to save money. Blindly live loading every joint in a plant will cost a great deal and is probably unnecessary. The following questions should be asked before deciding to live load a joint system:
 - a. Is joint failure a particular safety concern?
 - b. Will the joint be subject to large temperature fluctuations?
 - c. Is the length to diameter ratio of the bolt less than three?
 - d. Are any of the factors which rob a bolt of preload (elastic interactions, creep, etc.) prevalent in the system?
 - e. Does the joint have a history of maintenance problems?

Keep in mind that use of a Belleville may only correct one of many problems with the design. Live loading only improves the amount of preload maintained over time. Since low residual preload is one of the main reasons for joint failure, use of springs will reduce the risk of a problem. A case in point is an extensive study being conducted by a major oil company on the prevention of leaks in heat exchanger joints. Over several shutdowns, they changed out the gaskets on a number of their historically most troublesome exchangers. Variables such as use of Bellevilles, gasket design, assembly method, preload control procedures, bolt condition, etc. were tested for their effectiveness in preventing leaks. Results revealed that of 62 joints that utilized springs, 10 had developed leaks after 7 months (16%). Of the 22 joints that employed no Bellevilles, 9 were leaking (41%). The study also stated that only 1 of 35 (3%) joints which used Bellevilles and upgraded gasket designs³ leaked compared to 5 of 20 (25%) for the same gaskets with no springs. Use of springs clearly had a positive overall impact on the performance of the joint; however, using them with a better gasket all but eliminated the problem of leaks.

2. *A Belleville material must be chosen.* The obvious answer would be to employ the same material used for the bolt. However, since Bellevilles are normally made from materials which make good springs, this is not always possible. The manufacturers are also limited to materials which are readily available in strip form, although some Bellevilles are machined from bar or slugged from plate. The criteria for choosing an appropriate spring material are *basically* the same as those for a bolt. However, since the stresses in Bellevilles are normally higher than those in the bolts, the engineer should be more conservative when choosing a material. Susceptibility to stress corrosion cracking, creep, hydrogen embrittlement, etc. are increased at higher levels of stress. Some of the material properties and applications are listed below:

³These gaskets proved to be very resistant to unloading after thermal cycling.

- a. Carbon Steels (AISI 6150 and AISI 1074) - Operating range is from -40 to 350 F. These materials are used on indoor and outdoor applications at ambient temperatures. Their high strength and ductility leads to excellent spring properties. However, this also makes them susceptible to environmentally assisted cracking. For this reason, a corrosion protection such as mechanical plating is suggested.
- b. Corrosion Resistant Materials (Types 301 and 316 Stainless Steels) - Operating range is from -400 to 550 F. These materials are extremely resistant to rust and acids. They are slightly magnetic and obtain their strength through work hardening. For this reason, the thickness of the springs is limited.
- c. Antimagnetic and Corrosion Resistant Materials (510 Phosphor Bronze and Beryllium Copper) - Operating range is from -400 to 300 F. Phosphor Bronze is used with copper bus and silicon bronze bolts and nuts. Both materials have good electrical conductivity. Since their elastic moduli are much lower than those of carbon steels, flat loads will tend to be reduced.
- d. Precipitation Hardened Stainless Steels (Types 17-7PH and 17-4PH) - Operating range is from -400 to 550 F. These corrosion resistant and high strength materials are used in a wide variety of indoor and outdoor applications including live loading of flanges in cryogenic and high temperature service, live loading of valve stems, etc. Since they are susceptible to cracking in chloride and fluoride atmospheres, a surface protection such as sulfamate nickel plate is recommended if the springs are to be used near a seacoast.
- e. Hot Worked Tool Steels (H13 and H11 Tool Steels) - Operating range is from 250 to 1000 F. These Bellevilles are typically used in flange live loading where fasteners are subject to high loads and temperatures. Due to their thickness, these parts are usually machined.
- f. High Temperature Materials (Inconel 718 and X 750) - Operating range is from -400 to 1100 F. These Bellevilles are used in high temperature and corrosive service. They are also extremely resistant to environmentally assisted cracking. Due to their higher cost, however, use is usually reserved for critical applications.

- 3. *The inside and outside diameter limits should be established.* First, the I.D. of the Belleville should obviously coincide with the bolt size. Second, the O.D. should contact on a

flat, even surface. If there are any irregularities, or if the spring overhangs the joint section, the loading and deflection characteristics of the Belleville will be altered.

Some manufacturers offer outside diameters that are equal to the O.D. of the points on a standard nut. These "flange washers" prevent any interference problems on large heat exchanger flanges where the bolts are typically close together. They also are designed to have higher flat loads so the springs rarely have to be combined in parallel.

4. *A flat load for the Belleville Spring must be selected.* Most manufacturers offer more than one flat load for a given bolt size. Furthermore, multiple washers can be stacked in parallel to achieve varying flat loads. It is important to remember here that using Bellevilles only effects residual preload (as opposed to original preload). The springs only help maintain that preload over time. Therefore, the engineer may compute original preload as if no springs were used. Next, use a spring manufacturer's literature to find a spring or combination of springs with a flat load that is close to this preload figure.

The preload that is calculated will not always equal the flat load of any one spring. That's OK, the Belleville will still work if the loads are not exact. If preload is halfway between the flat loads of two springs, then choose the lower of the two flat loads¹. This may run contrary to intuition since engineers normally move up to the heavier sizes when designing a bolted joint. However, it is important to find a spring that will produce as much deflection as possible at a selected preload.

Using lower flat load yields two benefits. First, lighter washers will normally have more deflection available² (assuming equal O.D.'s). Second, the lighter Belleville will fully flatten at the selected preload, where the heavier spring will only partially deflect. Remember that as the fastening system deflection increases, residual preload also increases. Additionally, overloading the spring will not damage it, as would be the case with a bolt. It merely remains flat until the joint begins to move. Therefore, increasing the fastening system deflection by using lighter springs will result in a lower R/dLf ratio and less loss of preload.

When Bellevilles are not used, the formulas used to determine preload compensate for loss of load due to elastic interactions, etc [6][2]. In other words, the engineer adds in extra preload in anticipation of the gasket unload after the joint is put into service. The Belleville counteracts many of these losses by maintaining a higher degree of the original preload through a given movement in the joint. Therefore, the changes in preload due to elastic interactions,

¹Providing that the flat load of the lighter Belleville is higher than the calculated minimum preload.

²Due to permissible stresses in Belleville Springs the deflection h must decrease as the thickness t increases (assuming that material and other dimensions are held constant.)

embedment relaxation, differential thermal expansion, etc. will all be substantially reduced in a live loaded joint. Thus, if Bellevilles are used, the required original preload can be lower.

5. *The number of springs to be used in series on each bolt must be determined.* A good rule of thumb here is to use two: one at each end of the bolt. This will increase the deflection of the fastening system by a factor of 7 to 15, for a typical 300 lb. flanged joint. This increase in performance should be ample for almost any bolting application.

There are some cases where more than two Bellevilles should be used. Excessive movement in joint materials, short active bolt length, and high differential thermal expansion could demand even more deflection from the fastening system. The equation for the number of Bellevilles required in series is as follows (for a derivation of this formula, call Solon Manufacturing Co.):

$$N = \frac{F_W [R * E * A L_B * F_P * (IPR)]}{(IPR) * F_P * E * A * h}$$

where,

R = The sum of all the factors which loosen the joint (in inches.) These may include differential thermal expansion, gasket relaxation, bolt creep, elastic interactions, etc.

F_P = Original preload (in lbs.)

N = Number of Bellevilles (or Belleville sets) required.

h = Published deflection-to-flat of the Belleville (in inches.)

F_W = Published flat load of the Belleville (in lbs.)

L_B = Active length of the fastener (in inches.)

A = Root area of the fastener (sq. in.)

PR = The percentage of load we wish to retain.

This equation is accurate if the flat load of the Belleville F_W is greater than or equal to the preload F_P (because the slope of load vs. deflection changes after the spring becomes flat.) Note that the number that is computed should be rounded up to the next integer. If the answer is negative, then no washers are needed.

6. *An installation procedure for the Bellevilles should be developed.* These springs must be utilized correctly in order to maximize their benefit. There are several important points when live loading a joint:

- a. Be sure that bolts are long enough to account for the thickness of the Bellevilles!!

- b. The O.D. corner of the spring should contact the joint while the I.D. corner interfaces with the bolt head or nut (see Figure 26). If the crown of the Belleville is allowed to extend into the hole in the joint then its loading characteristics will be altered. The same is true for a nut that contacts the spring's bottom surface. Since deflections are relatively small, it is difficult for field personnel to see which side is up. Some manufacturers have incorporated chamfers or painted top surfaces to help field personnel determine the orientation of their springs.

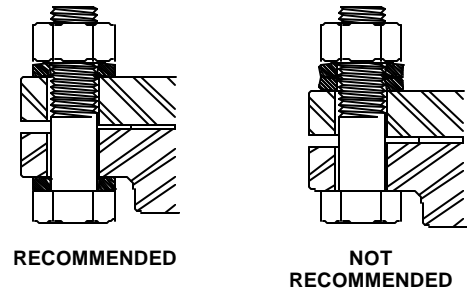

Figure 26 Two examples of proper and improper ways to install two Belleville Springs in series.

- c. If a tensioner is used to preload the bolts, then the Bellevilles must be on the opposite side of the joint. It is impossible for the tensioning device to apply load to a spring if it is located on the side that is being pulled.
- d. There are rare circumstances where Bellevilles of different thicknesses and flat loads should be used in series on the same bolt. For instance, when differential thermal expansion is extreme, a heavy spring that is only partially deflected will prevent the gasket or bolts from being overloaded while the system is heating up (Figure 27). On the same joint several lighter springs should be flattened to compensate for relaxation when the system cools. If this is the case care must be taken not to allow any of the lighter springs to be "pushed" past their flat position. This could result in yielding or even fracture of the spring material.

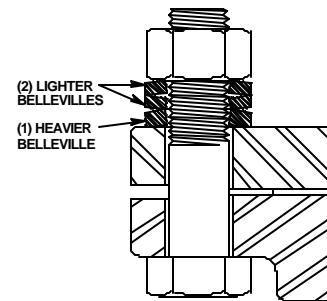

Figure 27 Drawing of how two lighter springs should be combined in series with one heavy spring.

4.1 A Practice Problem

The following scenario is an example of a typical live loading problem for a flanged joint. A heat exchanger joint in a petroleum refinery (near an ocean) has a history of leaking. The maximum operating temperature is 750 F. A flange with 16 1" B7 studs are used along with a spiral wound gasket with a graphite filler material. Spot faces on the flange surface are slightly larger than the points on the nut. The gasket manufacturer has recommended a bolt stress of 30,000 psi to seat the gasket. It is estimated that the cumulative effects of the factors which rob the bolt of its preload to be .010".

The first step is to determine whether the joint is a candidate for live loading. Since the flange has

had problems in the past with leaks it is decided that it is. Next, a Belleville material must be chosen. If the exchanger is not insulated the temperature at the bolt will probably be much lower than 750 F. There are several materials that will work within these constraints. However, precipitation hardened stainless steels should be eliminated due to their susceptibility to stress corrosion cracking in marine environments. Since a B7 bolt material is used, a similar H-13 tool steel is selected rather than an expensive inconel spring.

Next, a spring with an O.D. that is smaller than the spotface must be found so that it will interface with a flat surface. For a 1" bolt, the O.D. should be less than 1 7/8". Flat load for the spring should also be around 18,180 lbs (based on the gasket manufacturer's suggestion.) With these constraints a flange washer with an O.D. of 1.810" and a flat load equal to the recommended preload is chosen.

The equation to determine the number of Bellevilles to use in series is employed to check that two springs per bolt is adequate. The assembly parameters are as follows:

R = .010"
 F_p = 18,180lbs.
 h = .020"
 F_w = 18,180 lbs.
 L_B = 5
 A = .606
 PR = .75 (assumed)

Solving for N:

$$N = \frac{F_w [R * E * A L_B * F_p * (IPR)]}{(IPR) * F_p * E * A * h}$$

$$N = \frac{18,180 [.010 * 30,000,000 * 0.606 * 5 * 18,180]}{(10.75) * 18,180 * 30,000,000 * 0.606 * .020}$$

$$N = 1.75$$

Therefore, two washers must be used. Bolt stretch at 18,180 lbs. is found to be .005". Since R exceeds the total bolt stretch, N will never be less than 0. That is because without springs the bolts will become completely unloaded. Also note that N can become very large if the value for PR increases. For instance, if 95% retained preload was used 10 springs would be required.

5.0 REFERENCES

1. "Manual on Design and Manufacture of Coned Disk Springs (Belleville Springs) and Spring Washers," SAE HS 1582 First Edition, June 1988.
2. Bickford, J., "An Introduction to the Design and Behavior of Bolted Joints," Marcel Decker, Inc., New York, 1995.
3. Payne, J., "Bolted Joint Improvements through Gasket Performance Tests," NPRA Maintenance Conference, San Antonio, Texas, May 1992.
4. Bickford, J., "That Initial Preload - What Happens to It?," *Mechanical Engineering*, October 1983, p. 57.
5. Winter, R.J., "Gasket Selection - A Flowchart Approach," presented at the 2nd International Symposium on Fluid Sealing of Static Gasketed Joints," LaBaule, France, September, 1990.
6. Keywood, S., "Testing and Evaluation of PTFE-Based Gaskets for Chemical Plant Service," presented at the 5th Annual Technical Symposium of the Fluid Sealing Association, Fort Lauderdale, FL, October, 1994.
7. "ALCOA Aluminum Bus Conductor Handbook," Aluminum Company of America, Pittsburgh, PA, 1957.
8. Bickford, J., "Bolt Torque: Getting It Right," *Machine Design*, June 21, 1990, p. 67.
9. Bickford, J., "Tightening a Group of Bolts," *The Distributor's Link*.
10. Payne, J., "Traditional vs. New Bolt Load Calculations," presented at the ASME, PVP Conference, San Diego, CA, June, 1991.
11. Roberts, I., "Gaskets and Bolted Joints," *Journal of Applied Mechanics*, 1950.

Written for use in the Bolting Handbook
to be published in 1997 by Marcel Dekker.
John Bickford and Sayed Nassar, editors.

Solon Manufacturing Company
425 Center Street
Chardon, OH 44024
800-323-9717 FAX (440) 286-9047
(440) 286-7149